

NEOCLASSICO RICERCATO

IL VOLTO NUOVO DEL LEGNO MASSICCIO, OSSIA UNA PORTA CLASSICA REINTERPRETATA IN MODO ORIGINALE. L'INCONSUETA LINEARITÀ È COMBINATA CON INCISIONI E BUGNATI ESEGUITI IN PREVALENZA SU LEGNI CHIARI. IL RISULTATO È UNA COLLEZIONE LEGGERA E FORTE ALLO STESSO TEMPO, CAPACE DI ARRICCHIRE DEL FASCINO E DEL CALORE DEL LEGNO MASSICCIO, ANCHE L'AMBIENTE PIÙ MODERNO.

REFINED NEOCLASSICISM THE NEW LOOK OF SOLID WOOD, AN ORIGINAL REINTERPRETATION OF THE CLASSIC DOOR. THE UNUSUAL LINEARITY IS COMBINED WITH ENGRAVING AND ASHLARED PANELS MOSTLY ON LIGHT COLOURED WOODS. THE RESULT IS A LIGHT, YET STRONG COLLECTION CAPABLE OF ADDING THE CHARM AND WARMTH OF SOLID WOOD TO EVEN THE MOST MODERN SETTING.

NEOCLASSIQUE RECHERCHE LE NOUVEAU VISAGE DU BOIS MASSIF: UNE PORTE CLASSIQUE REVISITEE AVEC ORIGINALITE. L'INSOLITE LINEARITE SE MARIE AVEC LES INCISIONS ET LES BOSSAGES REALISES PRINCIPALEMENT SUR DES BOIS CLAIRS. LE RESULTAT EST UNE COLLECTION A LA FOIS LEGERE ET FORTE, CAPABLE D'APPORTER LE CHARME ET LA CHALEUR DU BOIS MASSIF A L'INTERIEUR LE PLUS MODERNE.

NEOCLÁSICO SOFISTICADO LA NUEVA IMAGEN DE LA MADERA MACIZA: UNA PUERTA CLÁSICA REINTERPRETADA DE MANERA ORIGINAL. LA INSÓLITA LINEALIDAD COMBINADA CON LABRADOS Y ALMOHADILLADOS, PREFERENTEMENTE EN MADERAS CLARAS. EL RESULTADO ES UNA COLECCIÓN LIGERA Y SÓLIDA A LA VEZ, CAPAZ DE EXALTAR EL ENCANTO Y LA CALIDEZ DE LA MADERA MACIZA HASTA EN LOS AMBIENTES MÁS MODERNOS.

EDLE KLASSIK IN NEUER OPTIK DAS NEUE GESICHT VON MASSIVEM HOLZ - EINE KLASSISCHE TÜR IN AKTUELLER INTERPRETATION. DIE UNGEWÖHNLICHE LINEARITÄT HARMONIERT PERFEKT MIT DEN KASSETTEN UND FRÄSUNGEN, VOR ALLEM AUF HELLEM HOLZ. DAS RESULTAT IST EINE KOLLEKTION, DIE LEICHT UND STARK ZUGLEICH IST, UND AUCH DAS MODERNSTE AMBIENTE MIT DER ZEITLOSEN FASZINATION UND WÄRME VON MASSIVEM HOLZ BEREICHERT.

ИЗЫСКАННЫЙ НЕОКЛАССИЧЕСКИЙ СТИЛЬ НОВОЕ ЛИЦО МАССИВНОГО ДЕРЕВА, ТО ЕСТЬ, ОРИГИНАЛЬНОЕ ПЕРЕОСМЫСЛЕНИЕ КЛАССИЧЕСКОЙ ДВЕРИ. НЕОБЫЧНАЯ ЛИНЕЙНОСТЬ СОЧЕТАЕТСЯ С РЕЗЬБОЙ И РУСТАМИ, ВЫПОЛНЕННЫМИ В ОСНОВНОМ НА ДЕРЕВЕ В СВЕТЛЫХ ТОНАХ. В РЕЗУЛЬТАТЕ ПОЛУЧАЕТСЯ ЛЕГКАЯ, И В ТО ЖЕ ВРЕМЯ ВНУШИТЕЛЬНАЯ КОЛЛЕКЦИЯ, СПОСОБНАЯ ОБОГАЩАТЬ ОЧАРОВАНИЕМ И ТЕПЛОМ МАССИВНОГО ДЕРЕВА ДАЖЕ САМЫЙ СОВРЕМЕННЫЙ ИНТЕРЬЕР.

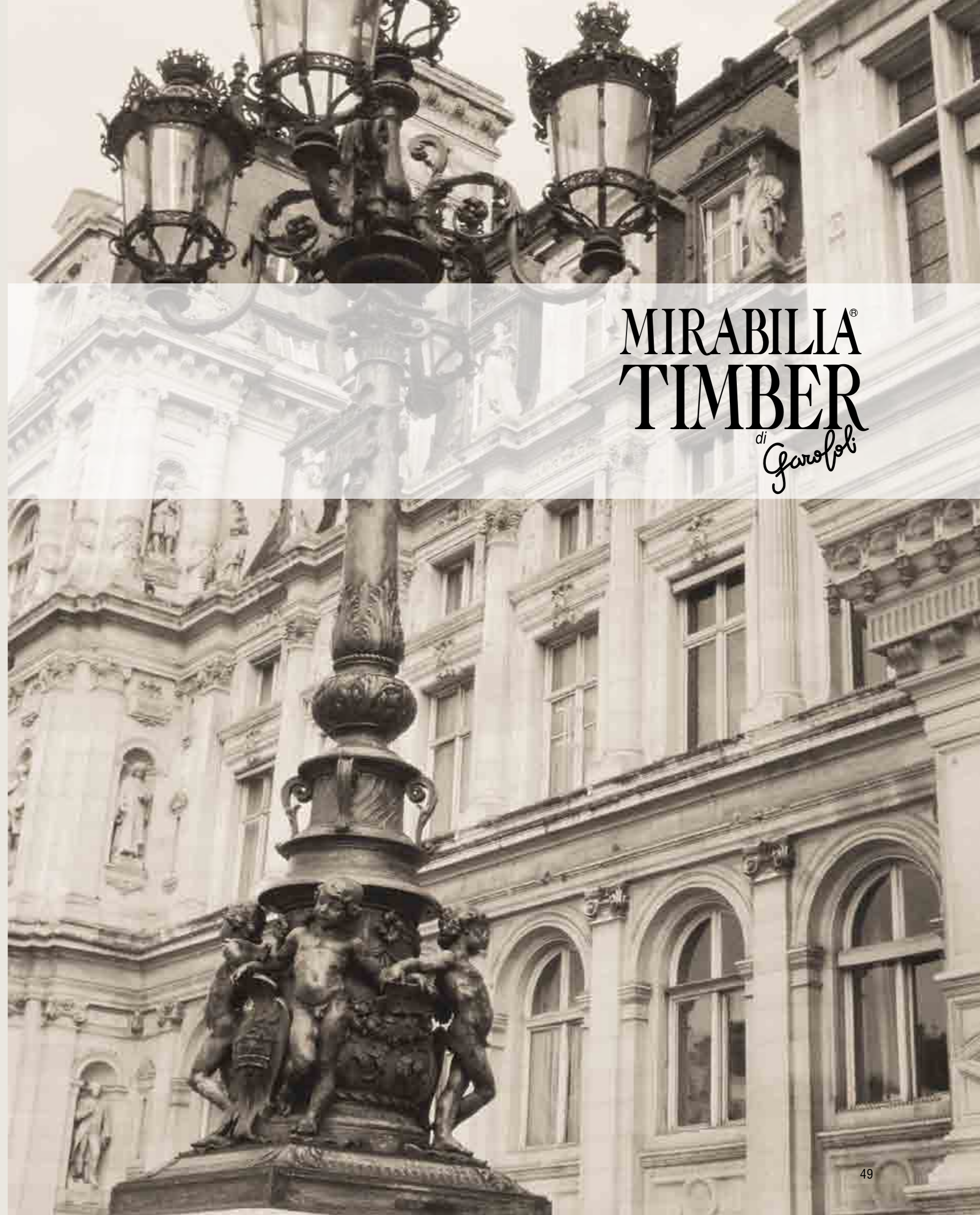

MIRABILIA[®]
TIMBER
di Garofoli



MOD. ASSUR 2BC
ASCERRY SCURO.
DARK ASCERRY.
ASCERRY FONCE.
ASCERRY OSCURO.
ASCERRY DUNKEL.
АМЕРИКАНСКАЯ ВИШНЯ ТЕМНАЯ.



EBLA 2B



ZUBI 1B1V



BASRA 1B6V



KLISSIA 3B2005



KUTA 2B6V



ASSUR 2BC



DUGA 1B1VC



AKKAD 1B6VC



VESSUA 1B1V2005



GEBEL 4B



MENUA 6B



URUK 2B1V



LUMMA 2BARCO



NANNIA
1B1VARCO



KUARA
1B6VARCO



URSU PORTA
LISCIA



URA 1V2001



DARA 1TV



1M2007



EBLA 2B



ZUBI 1B1V



BASRA 1B6V



KLISSIA 3B2005



VESSUA 1B1V2005



GEBEL 4B



MENUA 6B



URUK 2B1V

Colori legni . Colours . Coloris . Colores . Farben . Цвета

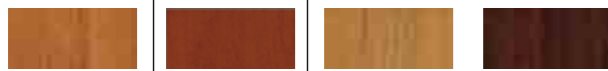

ASCHERRY CHIARO LIGHT ASCHERRY ASCHERRY CLAIR ASCHERRY CLARO ASCHERRY HELL АМЕРИКАНСКАЯ ВИШНЯ СВЕТЛАЯ	ASCHERRY SCURO DARK ASCHERRY ASCHERRY SOMBRE ASCHERRY OSCURO ASCHERRY DUNKEL АМЕРИКАНСКАЯ ВИШНЯ ТЕМНАЯ	ASCHERRY NATURALE NATURAL ASCHERRY ASCHERRY NATUREL ASCHERRY NATURAL ASCHERRY NATURAL АМЕРИКАНСКАЯ ВИШНЯ НАТУРАЛЬНАЯ	ARTE POVERA ARTE POVERA ARTE POBRE ARTE POVERA ARTE POVERA
---	--	--	--

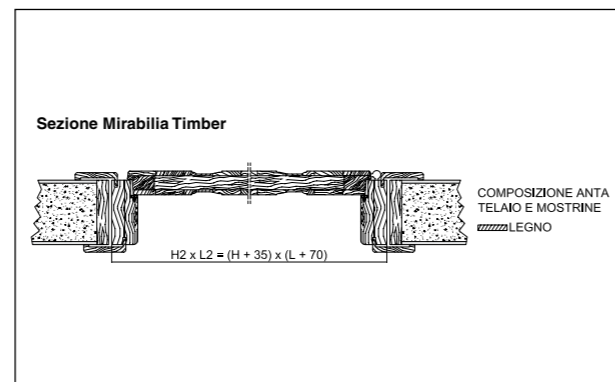



KUTA 2B6V



ASSUR 2BC



DUGA 1B1VC



AKKAD 1B6VC



URA 1V2001



DARA 1TV



1M2007



LUMMA 2BARCO



NANNIA
1B1VARCO



KUARA
1B6VARCO



URSU PORTA
LISCIA

Colori legni . Colours . Coloris . Colores . Farben . Цвета



ASCHERRY CHIARO
LIGHT ASCHERRY
ASCHERRY CLAIR
ASCHERRY CLARO
ASCHERRY HELL
АМЕРИКАНСКАЯ БИЛШІР
СБЕТЛАЯ



ASCHERRY SCURO
DARK ASCHERRY
ASCHERRY SOMBRE
ASCHERRY OSCURO
ASCHERRY DUNKEL
АМЕРИКАНСКАЯ БИЛШІР
ТЕМНАЯ



ASCHERRY NATURALE
NATURAL ASCHERRY
ASCHERRY NATUREL
ASCHERRY NATURAL
ASCHERRY NATUR
АМЕРИКАНСКАЯ
БИЛШІР НАТУРАЛЬНАЯ



ARTE POVERA
ARTE POVERA
ARTE POVERA
ARTE POVERA
ARTE POVERA

